

SECTION K

FRONT SUSPENSION

General Description.

Maintenance.

- | | |
|------------------|---|
| Section No. K.1 | Checking and adjusting front wheel alignment. |
| Section No. K.2 | Checking the wheel camber, castor angle and swivel pin angle. |
| Section No. K.3 | To measure camber. |
| Section No. K.4 | To measure castor angle. |
| Section No. K.5 | To measure king-pin inclination. |
| Section No. K.6 | Removing the front suspension. |
| Section No. K.7 | To dismantle the swivel pins. |
| Section No. K.8 | Examination of front suspension parts for wear. |
| Section No. K.9 | Hub ball bearings. |
| Section No. K.10 | Replacing the front suspension. |
| Section No. K.11 | Reassembly of swivel pins. |
| Section No. K.12 | Removal and replacement of the brake-drum and hub. |
| Section No. K.13 | Replacement of the front hub. |
| Section No. K.14 | Removing and replacing the front coil spring. |
| Section No. K.15 | Fitting new rubber bushes to lower wishbone inner fulcrum. |
| Section No. K.16 | Grease leakage from front hub. |
| Section No. K.17 | Modified front hub grease cap. |

GENERAL DESCRIPTION

The independent front suspension layout is of the wishbone type, incorporating coil springing. The front wheels follow the road surface without influencing each other, and each wheel is permitted to rise and fall vertically. It gives perfect stability with riding comfort, and by the combination of the direct-acting rack-and-pinion steering gear it also provides light and accurate control under all conditions.

The inner mountings of the lower wishbones are fitted with flexing rubber bearings, which require no lubrication and form a silent and resilient connection to the robust box-section chassis frame cross-member.

The steering swivels, or king-pins, are of a special design, with the top and bottom bearings threaded to provide large bearing areas and absorb both thrust and journal loads. The swivel pin threads are of opposite hand on each side of the car and are therefore not interchangeable. The steering connection from wheel to wheel is provided by the steering gearbox rack bar and two short track-rods, with ball joints at each end. The outer ball joints are fitted with grease gun nipples, but the inner ball sockets are enclosed in the telescopic rubber dust excluders and automatically lubricated from the steering gearbox.

MAINTENANCE

In ordinary maintenance it is unlikely that it will be necessary to do more than attend to replenishment as indicated in Section P.6, and check the front wheel alignment. This is the setting that may be affected by striking high kerbs or similar obstacles.

In view of the importance of maintaining the correct steering geometry the use of special locating jigs as indicated in Fig. K.2 is strongly advised when checking and setting.

Section K.1

CHECKING AND ADJUSTING FRONT WHEEL ALIGNMENT

When checking the track width at the front and the rear of the front wheels, use a suitable trammel, or any special proprietary alignment equipment available.

The wheels should run parallel and have no toe-in. The correct setting is obtained with equal measurements back and front.

See that the tyres are inflated to the correct pressures.

Set the wheels in the straight-ahead position.

Set the arms of a suitable trammel to the height of the hub centre.

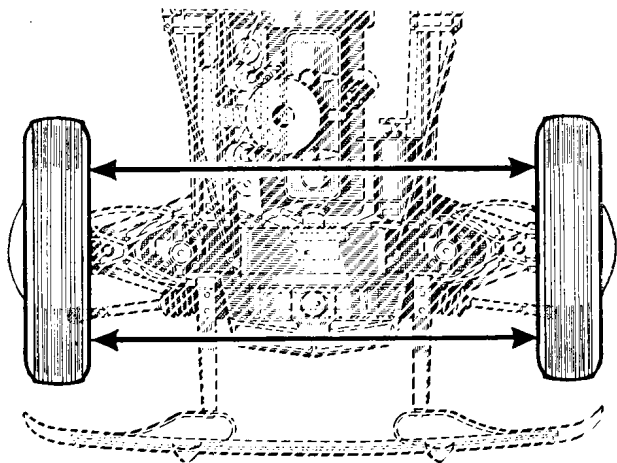

Fig. K.1.

The front wheels should be set so that they are exactly parallel to each other when in the straight-ahead position.

Place the trammel to the rear of the wheels and adjust to the centre of the tyre treads. Chalk the tread of the tyres and mark chalked patch with the trammel vertically. Push the car forward one half-turn of the wheels and take the front reading from the same marks on the tyres.

If adjustment is necessary, proceed as follows:—

Slacken off the locknuts at the ends of the short tie-rods.

By means of the spanner flats on the rods, **rotate each of the tie-rods equally** in the desired direction. These both have right-hand threads.

Note.—To ensure that the steering gearbox rack is in the central position and that the steering geometry is correct, it is important that the tie-rods are adjusted to exactly equal lengths. This can be ascertained by measuring from the end of the flats to the locknuts.

Section K.2

CHECKING THE WHEEL CAMBER, CASTOR ANGLE AND SWIVEL PIN ANGLE

If, due to accident or collision, it is thought necessary to check the steering angles, we recommend the use of any of the good proprietary equipment available for this purpose, such as the "Dunlop" Wheel Camber, Castor and King-pin Gauge. Each maker provides full instructions on the use of their instrument, to which you should refer.

Section K.3

TO MEASURE CAMBER

In the static position the wheel has no camber (tolerance $\pm 1^\circ$), but from this static position to full bump or rebound the camber changes as a result of the geometry of the suspension.

Ensure that the tyre inflation pressures are correct and that the load on the axle is 9 cwt. 3 qr. (495 kg.).

Make sure also that the wheels are in the straight-ahead position when the check is made.

Repeat this procedure on the other wheel.

Section K.4

TO MEASURE CASTOR ANGLE

In the static position this angle is $2^\circ \pm \frac{1}{2}^\circ$.

Check that the vehicle is on a level surface, that the front wheels are in line with the rear wheels, i.e. in the straight-ahead position, that the tyres are correctly inflated, and that the load on the axle is 9 cwt. 3 qr. (495 kg.).

Section K.5

TO MEASURE KING-PIN INCLINATION

In the static position this angle is 9° , but from full bump to rebound this varies by $1\frac{1}{2}^\circ$, making it important to take the measurements **with the correct load on the axle.**

Note.—To ensure correct checking of the steering angles we recommend the use of locating jigs and jacks. This ensures that the chassis frame is square and in the correct static position. Their method of application is clearly shown in Fig. K.2.

Place the car on a flat surface, remove the rear wheels and drop the frame down onto the screw-type jack (Fig. K.2).

Place the front support under the centre of the front suspension wishbone pivots. Weight down or pull down the front end of the car firmly onto the front support. Use manually operated jacks at the points shown to relieve the tyre grip when swinging the wheels to check the angles and to bring the frame members parallel to the ground surface.

hydraulic damper levers are just clear of the rebound rubbers.

Disconnect the hydraulic brake hoses. (See correct method explained on page M.12.)

Slacken the steering tie-rod nuts and screw the tie-rods out of the steering ball joints by means of the flats on the rods.

Remove the cotters and nuts from the two outer fulcrum bolts. Draw out the bolts and take away the front hub and swivel pin units complete. (Take care of the thrust washers, rubber seals, retainers and fulcrum pins.)

Release the jacks from under the spring pans.

Press down the lower wishbone assemblies and remove the coil springs.

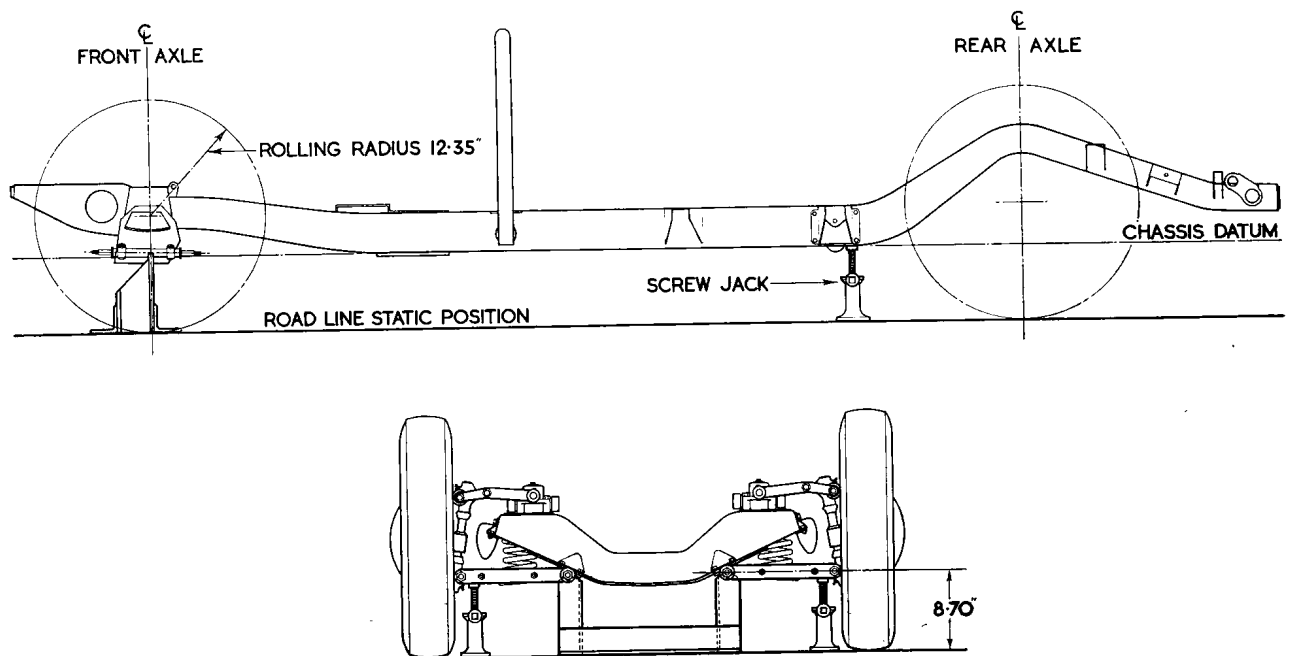

Fig. K.2.

The use of special locating jigs to set the chassis in its correct position for checking the steering geometry is advised to ensure the best results.

Section K.6

REMOVING THE FRONT SUSPENSION

Jack up the front of the car by a suitable jack placed under the centre of the front cross-member, until the front tyres are just clear of the ground.

Remove the front wheels. Block up under chassis.

Place two additional jacks under the spring pans (position as shown in Fig. K.8).

Jack these up, taking some of the weight, until the

Remove the four bolts holding the spring pan to the levers.

Remove the cotters, nuts and washers from the ends of the inner lower fulcrum pin and slide off the levers and the rubber bushes.

Remove the bolts holding the lower fulcrum pins to the chassis cross-member.

Remove the bolts holding the hydraulic dampers to the top of the chassis cross-member.

Inside the outer ends of the front cross-member will be found the coil spring locating plates. These are each attached by one small bolt.

THE FRONT SUSPENSION

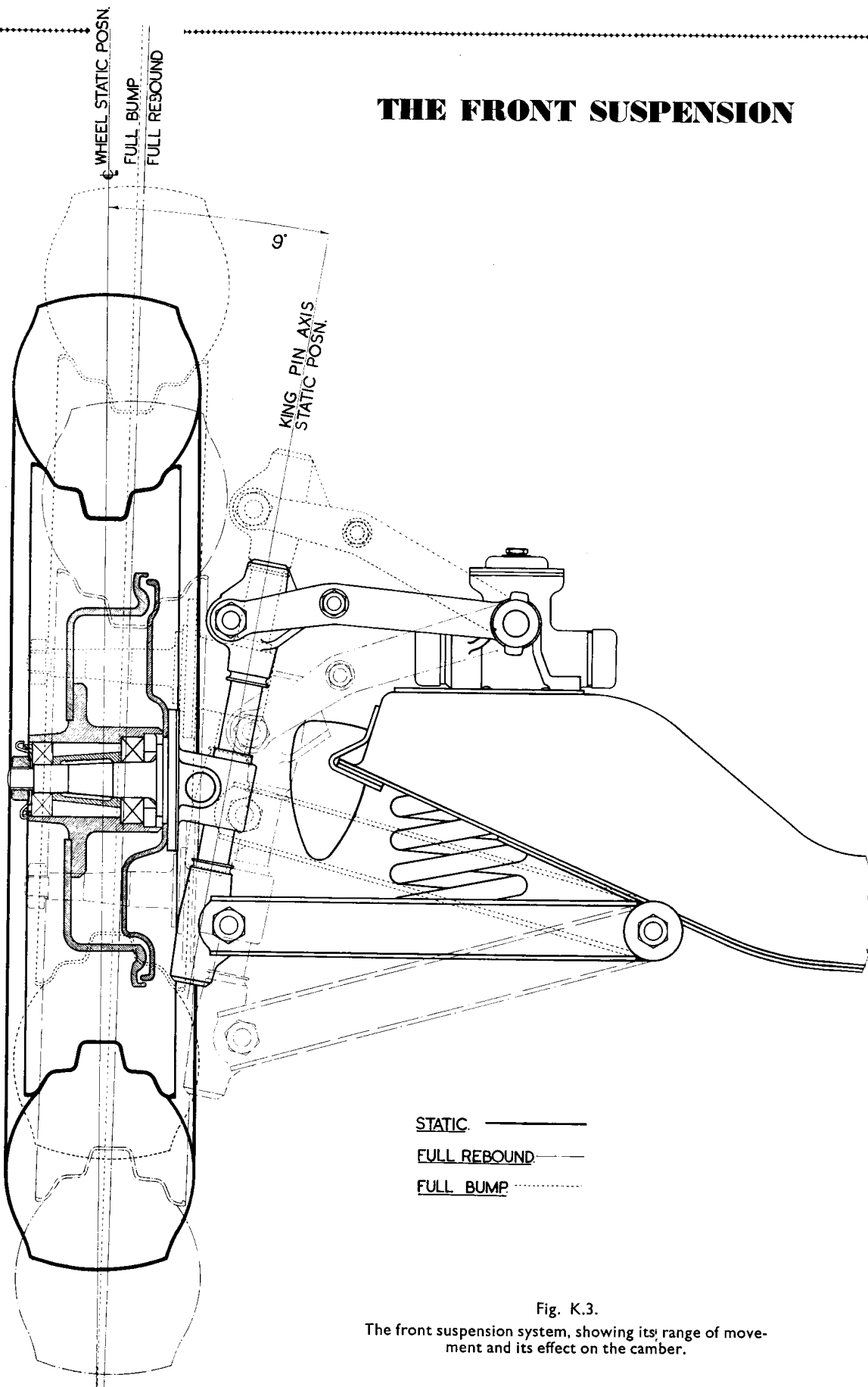

STATIC ———
 FULL REBOUND - - -
 FULL BUMP
 ———

Fig. K.3.
 The front suspension system, showing its range of movement and its effect on the camber.

Section K.7

TO DISMANTLE THE SWIVEL PINS

Unscrew the upper and lower links from the ends of the swivel pins. **The left-hand swivel pin has a left-hand thread at each end.**

The stub axle is located by a collar on the swivel pin and the stem of the steering lever engaging a groove in the pin. To separate the two the steering lever must be withdrawn from the stub axle, but this procedure is not advised unless absolutely necessary.

Section K.8

EXAMINATION OF FRONT SUSPENSION PARTS FOR WEAR

The following parts should be examined before reassembly :—

Bushes for bottom wishbone

If these are split or perished, eccentric, or oil-soaked, they should be renewed. A bush in new condition should have the dimensions given in Fig. K.10.

Bottom wishbone

Examine the end holes for elongation and the assembly for looseness. If there is any sign of slackness between the wishbone arms and the pan, separate the components and check the bolt holes for elongation. The bolt holes are $\frac{21}{32}$ in. (8.33 mm.) dia.

Coil spring

Examine for cracks and check for tension, if necessary, to details below. Renew the springs if they are defective.

Free length	9.59 in. $\pm \frac{1}{16}$ in.
Loaded to 1,095 lb. (496.7 kg.)				6.44 in. $\pm \frac{1}{32}$ in.

Swivel link assemblies

Check the swivel links. The dimension across the thrust faces should be 2.327 in. $\pm .0015$ in. (59.11 mm. $\pm .04$ mm.). If these are appreciably worn the assembly of link and bush should be renewed. If the bush only is worn, a new one should be pressed in and reamed and burnished to .750 in. $\pm .0005$ in. (19.05 mm. $\pm .01$ mm.).

Note.—When pressing in this bush see that the hole in the bush faces the threaded bore. (See Fig. K.4.)

Check the threaded bores on the swivel pins. When new, these are a free turning fit without slack. An appreciable amount of slack is permissible in these threaded bearings and they do not require renewal unless they are very slack.

Check the fulcrum pin distance tubes for scoring or wear. These should be 2.337 in. $\pm .0015$ in. (59.36 mm. $\pm .04$ mm.) long by .7485/.7480 in. (19.01 mm./19.00 mm.) diameter.

Examine the case-hardened thrust washers for ridges ; the faces should be flat and parallel within .0005 in. (.01 mm.).

The thickness should be .068 in./066 in. (1.73 mm./1.68 mm.), the bore .510 in./505 in. (12.95 mm./12.83 mm.) and the outside dia. 1.25 in. (31.75 mm.).

When the swivel links, distance tubes and thrust washers are assembled, the **total** end clearance between the link and the thrust washers should be .008 in. to .013 in. (.2 mm. to .33 mm.). (See "A," Fig. K.4.)

Check that all grease nipples are clear.

Examine the rubber seals, and if these are perished or split, renew them.

Section K.9

HUB BALL BEARINGS

As far as possible, bearings which come under review during the overhaul of the car should be cleaned and inspected without being withdrawn from the housings to which they are fitted. Unnecessary withdrawal causes deterioration of the fitting surfaces, and may damage the bearing, whereas if bearings are examined in position and found still to be serviceable, they can be left undisturbed with advantage.

Rust on the exterior surfaces of the bearing is not detrimental unless the fit is affected, but if the tracks, balls or rollers are severely pitted, the running life of the bearing is at an end and a new one should be fitted.

Ball bearings should be cleaned thoroughly with paraffin. Bearings which have been washed in this manner should be rinsed thoroughly and dried, and should be immersed in mineral oil as soon as possible after they have been examined.

After cleaning, bearings should be examined for cracks in the races, chipped or broken balls, and worn or damaged tracks or cages.

If either race is cracked or chipped, or if the tracks have spalled or flaked, the bearing should be scrapped.

Section K.10

REPLACING THE FRONT SUSPENSION

Bolt up the coil spring top locating plates inside the front cross-member.

Bolt on the hydraulic dampers.

K THE FRONT SUSPENSION

The dampers are interchangeable from side to side.

Bolt up the lower fulcrum pins. The two rear inner bolts have their nuts uppermost and the six other bolts have their nuts below.

Fit the rubber bushes into the lower levers. These bushes will be found to be quite a loose fit in the lever, but when clamped up by the nut and washer will expand into their housing. These bushes do not rotate on their surfaces, the angular movement being taken up by the rubber itself flexing.

Special care should be taken when assembling these bushes to maintain a central location, so that the expansion of each half of the bush is equal.

To attain this insert each bush so that it protrudes equally each side of the housing (see Fig. K.5), and then clamp up with the washer and nut and fit the cotter pins. When central, the outer flanges of the bushes should all be of equal proportions.

It is essential to clamp up the bushes when the lower suspension levers are set parallel with the ground to ensure even stresses on the bushes in service.

Fit the spring pans between the levers, but with the heads of the bolts inside the spring pan.

Do not tighten up the spring pan bolts solid, but leave them half a turn slack.

Press down the lower wishbone assemblies.

Smear each end of the coil springs with grease to prevent any slight squeaking in operation.

Push the coil springs up into the cross-member and over the locating plates.

Jack up the lower wishbone assemblies to the position shown in Fig. K.2 until they are approximately parallel to the ground.

Assemble the hub units and swivel pins as detailed in Sections K.11 and K.13.

Note.—The stub axle and nut is right-hand thread for the right-hand side and left-hand thread for the left-hand side.

The king-pin bearing threads are also right-hand thread for the right-hand side and left-hand thread for the left-hand side.

Fit the front hub units to the suspension levers.

Ensure that the thrust washers, rubber seals and

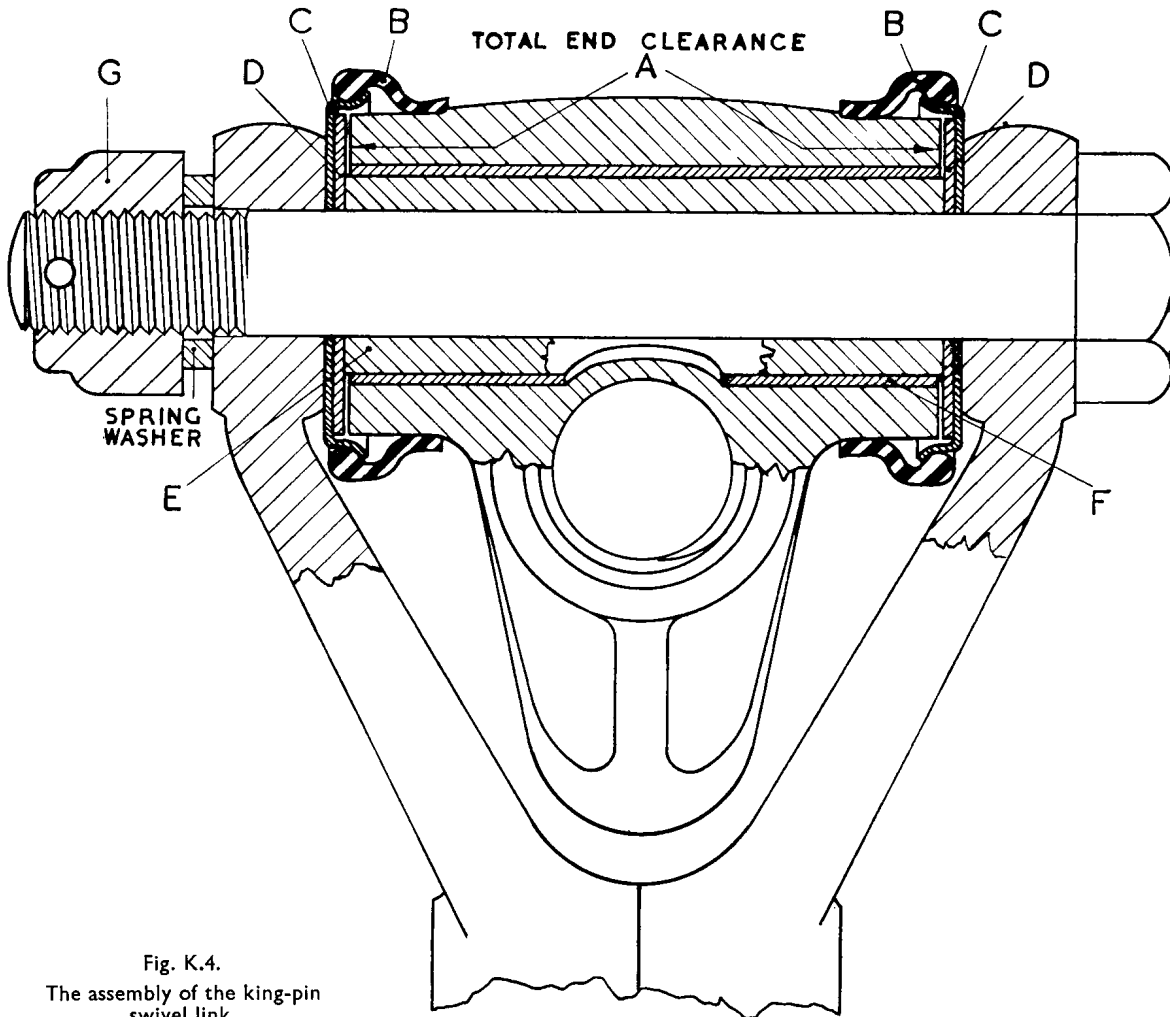

Fig. K.4.
The assembly of the king-pin swivel link.

retainers are assembled in the right order. (See Fig. K.4.)

Lubricate these parts and the fulcrum pins during assembly and again afterwards with the grease gun, using the recommended lubricant as detailed on page P.2.

Do not tighten up the top or the bottom slotted nuts solid, but leave them half a turn slack.

Connect up the hydraulic brake hoses. See correct method as explained on page M.12.

Screw the steering tie-rods into the outer steering ball joints. Screw the rods right in and then slack off five complete turns. This will give a rough wheel alignment and render subsequent accurate alignment easier.

Bleed and adjust the front brakes as detailed in Sections M.2 and M.3.

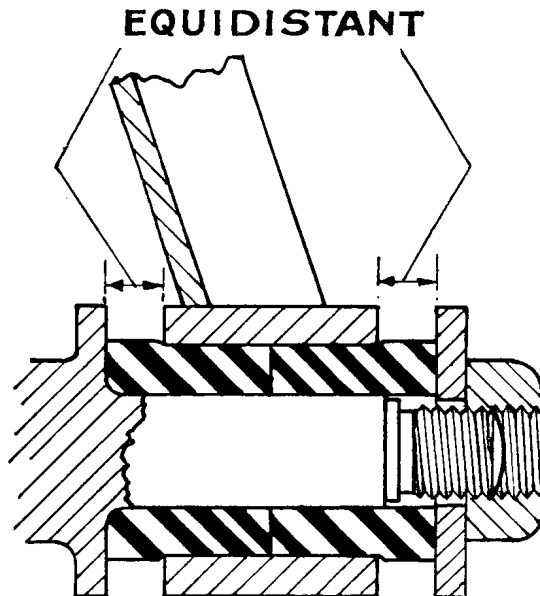

Fig. K.5.

The correct method of clamping the rubber bushes of the lower suspension arm.

Fit the front wheels.

Bounce the front end of the car up and down a few times. This allows the suspension fulcrums to settle down.

Now tighten the spring pan bolts and then tighten and cotter up the outer fulcrum bolts.

Check and adjust the front wheel alignment as detailed in Section K.1.

Section K.11

REASSEMBLY OF SWIVEL PINS

The swivel pin assembly may be reassembled without difficulty by carrying out the removal instructions in

the reverse order, provided the following points are given special attention :—

1. The swivel pin and links fitted to the left-hand side of the car have left-hand threads at each end and those fitted to the right-hand side have right-hand threads.
2. The swivel pin links screw onto threads on each end of the swivel pin and the threads are waisted at their centre to avoid fouling the pivot bolts passing through the links. Before the pivot bolt is replaced the link must be correctly positioned on the thread.

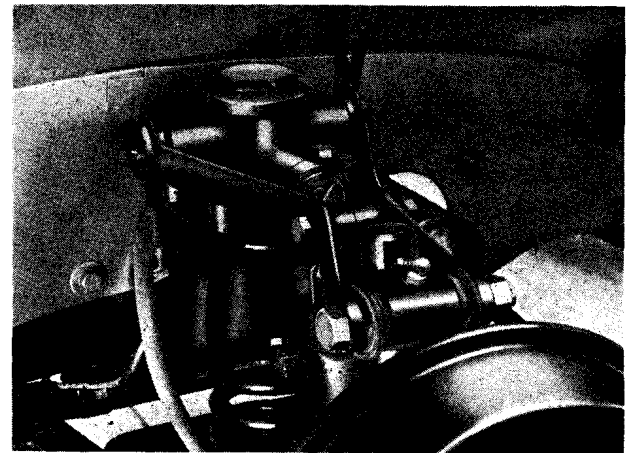

Fig. K.6.

The upper suspension arm assembly.

First screw the link onto the swivel pin until the waisted portion of the pin lines up with the pivot bolt hole.

Place the pivot bolt in position in the link and screw the link to the extent of its maximum travel on the swivel pin thread; this is about three revolutions total. Screw the link back approximately one and a half times to obtain the maximum clearance for the pivot pin in each direction.

If the brake plate has been removed from the swivel pin assembly, the lower link must also be centralised in a similar manner before the brake plate is replaced and before the swivel pin is fitted to the suspension arm.

3. Before the lower steering knuckle link is bolted in position ensure that both thrust washers and rubber seals are fitted correctly (see Fig. K.4) and make sure that the links have a total end clearance of .008 in. to .013 in. (.2 mm. to .33 mm.) between the end faces of the link and the thrust washers.

Note.—Make sure to locate the lower link assembly correctly because it cannot be set once the brake back plate is fitted.

K THE FRONT SUSPENSION

Section K.12

REMOVAL AND REPLACEMENT OF THE BRAKE-DRUM AND HUB

Prise off the hub cover by inserting the flattened end of the wheel nut spanner in the depressions provided adjacent to the cover holding studs and giving a side-ways twist—not a radial movement.

Slacken the wheel stud nuts.

Raise the car until the wheel to be operated on is clear of the ground.

Unscrew the stud nuts and remove the wheel.

The brake-drums are attached to the wheel hubs by countersunk-headed screws, the inner ends of which

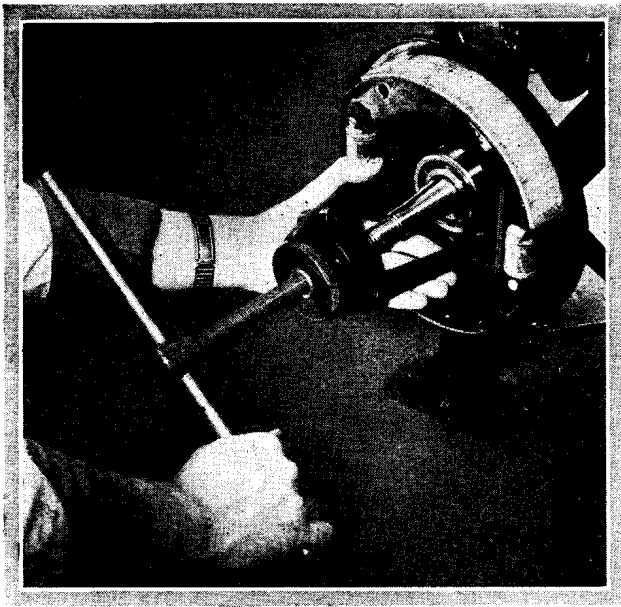

Fig. K.7.

Removing the front hub inner bearing with an extractor.

are riveted over. These screws must not be disturbed and a complete brake-drum and hub assembly must be used for replacement. The brake-drum, complete with hub, must be removed to give access to the brake-shoes. In some cases the hub and brake-drum are cast in one piece.

Remove the split pin from the stub axle nut and unscrew the nut, remembering that the axle on the left-hand side of the car has a left-hand thread.

Remove the grease retaining disc and felt washer.

Place the hub extractor (Special Tool, Part No. 68822) in position over the wheel studs and replace the stud nuts to retain it in position. Use the central extractor screw to withdraw the brake-drum and hub assembly.

The inner ball race bearing spacer and oil seal will remain on the stub axle and must be withdrawn with the aid of a separate extractor of the type shown in

Fig. K.7 ; this is the special service extractor Part No. 68895 (see Section Q). Care must be taken not to damage the oil seal at the rear of the bearing.

Important.—When the front hub has been removed the inner bearing, oil seal and hub distance washer **must** be removed from the stub axle and replaced in the hub before it is refitted to the stub axle. If the hub is pressed on the shaft without first fitting the bearing and oil seal to it, the inner bearing will re-enter its housing but the oil seal will only be pushed farther from its correct position.

Section K.13

REPLACEMENT OF THE FRONT HUB

If all grease has been cleaned from the hub and the bearings washed for examination, ensure that they are repacked with grease before the hub is reassembled.

Replace the bearing spacer with the chamfered side towards the small outer bearing and then press the large bearing into position. Replace the oil seal and

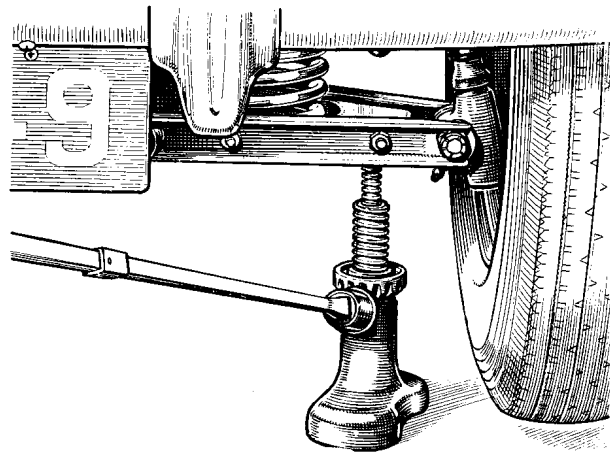

Fig. K.8.

The correct location of the jack when jacking up the front suspension.

distance washer. The metal face of the oil seal and the recessed side of the distance washer are fitted away from the bearing.

Replace the hub on the stub axle shaft and fit a new felt washer. Refit the grease retainer and replace and tighten the hub nut.

Section K.14

REMOVING AND REPLACING THE FRONT COIL SPRING

Jack up the front end of the car until the wheels are clear of the ground, using a suitable jack placed under the centre of the front cross-member.

Remove the front wheel on the side affected.

Place an additional jack under the lower spring pan in the position shown in Fig. K.8 and jack up until the hydraulic damper levers are clear of the rebound rubber.

Remove the lower fulcrum bolt.

Swing up the hub unit and rest on a suitable block.

Release the jack from under the spring pan, press down the lower wishbone assembly and remove the coil spring.

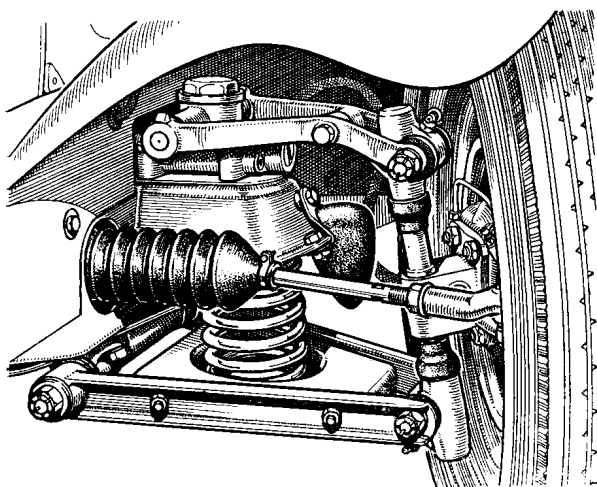

Fig. K.9.
The front suspension assembly.

Replacement is carried out in the reverse manner to that detailed for removal.

Note.—Take care that the thrust washers, rubber seals and retainers are assembled in the right order. (See Fig. K.4.)

Lubricate these parts and the fulcrum pins during and after assembly with the grease gun.

Smear each end of the coil spring with grease.

Section K.15

FITTING NEW RUBBER BUSHES TO LOWER WISHBONE INNER FULCRUM

Remove the coil springs as detailed in Section K.14.

Remove the four bolts holding the spring pan to the levers.

Remove the cotters, nuts and washers from the ends of the inner lower fulcrum pin and slide off the levers and the rubber bushes.

Fit the new rubber bushes into the levers. These will be found to be quite a loose fit in the lever, but when clamped up by the nut and washer will expand into their housing. These bushes do not rotate on their surfaces, the angular movement being taken by

the rubber deflecting torsionally in itself. Special care should be taken when assembling these bushes to maintain a central location, so that the expansion of each half of the bush is equal.

To attain this, insert each bush so that it protrudes equally each side of the housing (see Fig. K.5), and then clamp up with the washer and nut. When central, the outer flanges of the bushes should be of equal proportions.

It is essential to clamp up the bushes when the suspension levers are set parallel with the ground to ensure even stresses on the bushes.

Now fit the spring pan between the levers, but with the heads of the bolts inside the spring pan.

Do not tighten up the spring pan bolts solid, but leave them half a turn slack.

Press down the lower wishbone assembly.

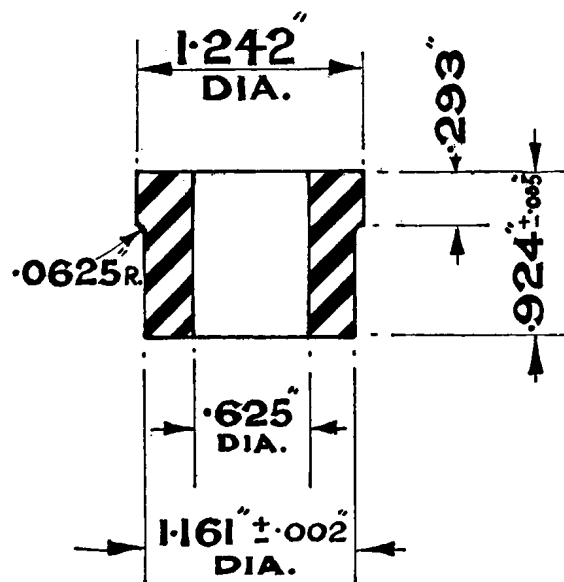

Fig. K.10.
The dimensions of the lower wishbone bushes when in new condition.

Smear each end of the coil spring with grease, and push the spring up into the front cross-member and over its top locating plate.

Jack up the lower wishbone assembly until it is approximately parallel to the ground.

Swing down the hub unit and fit the lower fulcrum bolt.

Note.—Take care that the thrust washers, rubber seals and retainers are assembled in the right order. (See Fig. K.4.)

Lubricate these and the fulcrum pin during and after assembly with the grease gun.

Remove the jack from under the wishbone assembly.

Finally tighten up the spring pan bolts, and insert the split cotter pins in all castellated nuts.

Section K.16

GREASE LEAKAGE FROM FRONT HUB

The front hubs on earlier models have been subject to grease leakage from the outside felt, and later cars have a grease cap fitted to the hub end which eliminates this trouble.

For existing cars without grease caps a special service cap is available which is retained in position by a spring and provided with a rubber sealing gasket, as indicated in Fig. K.11.

The Service Parts for this conversion, per car, are as follow:—

500196	Seal	2 off
500195	Grease retainer cap	2 off
500198	Spring clip	2 off
434/F	Split pin ($\frac{1}{8}$ in. \times $1\frac{1}{8}$ in.)	4 off
500328	Washer	2 off
500197	Distance tube	2 off

(for one-piece hub and drum only).

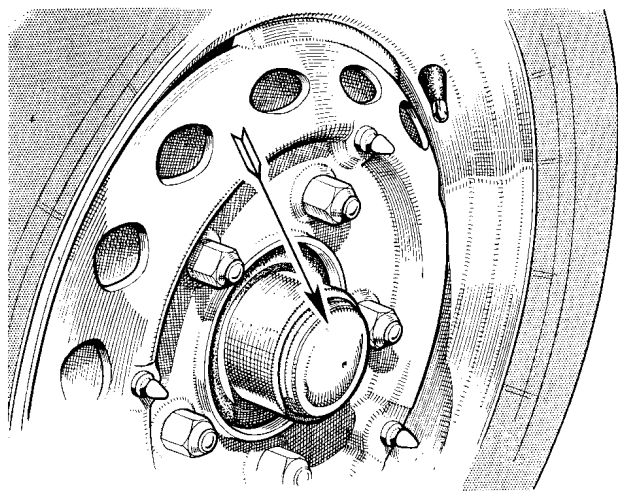

Fig. K.12.

The modified grease retaining cap fitted to the front hub of later models.

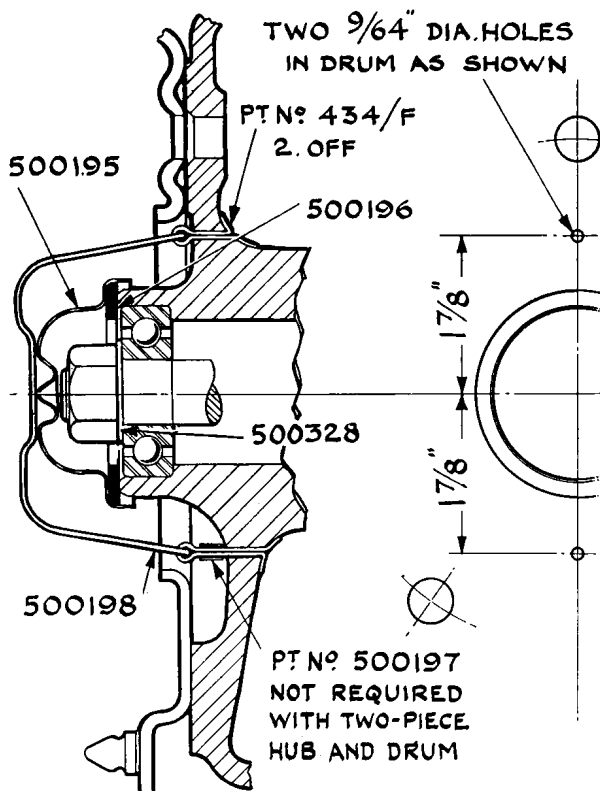

Fig. K.11.

The method of fitting the oil seal on the front hub of early models.

Section K.17

MODIFIED FRONT HUB GREASE CAP

Later models are provided with grease caps which are a push fit on the end of the front hubs, and these have to be prised off carefully for replenishment with grease at intervals of 6,000 miles (10000 km.). Use one of the greases recommended under Ref. C (page P.2).